

# CALJAN BELTRACK

## TELESCOPIC BELT CONVEYOR

### Speedy turnaround

Automation combined with ergonomic operation more than doubles capacity compared to manual loading/unloading.

### Focus on safety

To prevent accidents, pinch areas are minimal and covered. Chains and other moving parts are encased or shielded.

### Ergonomic operation

Using a joystick the operator is able to adjust height and extension to the optimal working position.

### Range of options

Individual requirements can be catered to by fitting options such as hydraulic elevation, DroopSnoot, hood and lighting.



## RELIABLE AND EASY TO USE – THE SAFEST CONVEYOR IN THE INDUSTRY

Although we develop our machines with a view to efficiency, we NEVER compromise on safety. On average, every accident in the dock area costs € 4,200, so investing in safe equipment is not only a question of looking after your staff, it is also economically sound. Reaching up to 16.7 m, Caljan SAFetrack conveyors enable you to load/unload all European trucks and trailers. With more than 16,000 units in use, Caljan BeltTrack is the world's most popular telescopic belt conveyor.



**Quality**  
Trolleys fitted with double bearings help spread the load of the telescopic sections whilst the booms are extending, providing uniform high performance throughout the conveyors lifetime.



**Safety**  
The design, with shielded underside, brushes at gaps, encased chains and guarded moving parts, is protected by patent No. EP1559666. European Safety and EMC requirements are fully adhered to.



**Service**  
A well-established service network, ensures that qualified technicians can be on hand as required.

# RANGE

## Dimensions

Type	L1	L2	L	A	B	C	Max. $\alpha^\circ$
<b>2-sections</b>							
CB2L-3/2.3*	3000	2300	5300	450	C+330	600/800	+10°/-10°
CB2L-4/2.5*	4000	2500	6500	450	C+330	600/800	+10°/-10°
CB2H-7/5.2*	7000	5200	12200	550	C+330	600/800	+5°/-2°
<b>3-sections</b>							
CB3L-2.3/2.5*	2300	2500	4800	550	C+330	600/800	+7°/-7°
CB3L-3/4*	3000	4000	7000	550	C+330	600/800	+7°/-7°
CB3L-4/5*	4000	5000	9000	550	C+330	600/800	+7°/-7°
CB3M-5/7	5000	7000	12000	550	C+342	600/800	+5°/-5°
CB3M-6/8.4	6000	8400	14400	550	C+342	600/800	+5°/-5°
CB3H-7.7/12	7700	12000	19700	660	C+342	600/800	+4°/-2°
<b>4-sections</b>							
CB4M-4/7	4000	7000	11000	720	C+388	600/800	+5°/-3°
CB4M-5/10	5000	10000	15000	720	C+388	600/800	+5°/-3°
CB4M-6/12.3	6000	12300	18300	720	C+388	600/800	+5°/-2°
CB4H-7/14.3	7000	14300	21300	750	C+388	600/800	+5°/-2°
CB4H-7.5/15.3	7500	15300	22800	750	C+387	600/800	+5°/-2°
CB4H/7.9/15.3, F	7900	15300	23200	750	C+387	600/800	+5°/-2°
<b>3-sections</b>							
CB3X-7.6/12.6	7600	12600	20200	900	C+450	600/800	+4°/-0.5°
<b>4-sections</b>							
CB4X-7/15.6	7000	15600	22600	900	C+450	600/800	+4°/-0.5°
CB4X-7.6/16.7	7600	16700	24300	900	C+450	600/800	+4°/-0.5°
<b>5-sections</b>							
CB5X-4.6/12.6	4600	12600	17200	900	C+450	600/800	+4°/-0.5°
<b>6-sections</b>							
CB6X-4.025/13.2	4025	13200	17225	900	C+550	600	+4°/-0°

\* Earlier models

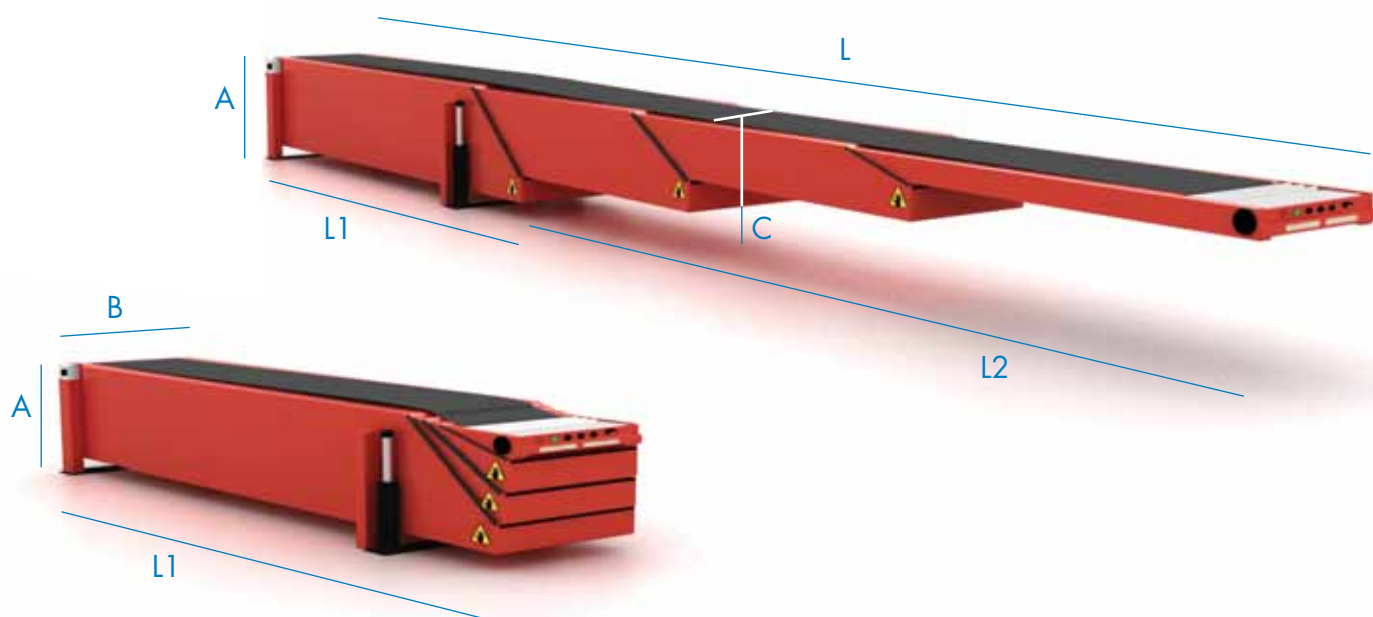

# OPTIONS



## Hydraulic Elevation

Powered by a hydraulic pump, the whole conveyor can be elevated at an angle of up to 10° ensuring that the operator can work in an ergonomic position. The elevation movement is controlled by means of the joystick fitted on either the right or left side of the boom. The same joystick is used to control extension/retraction.



## Vaculex ParcelLift™

Vaculex ParcelLift™ lifting aid helps the operator move items weighing up to 40 kg to and from the conveyor belt ergonomically, so that undue exertion is avoided and the risk of repetitive strain injuries (MSD) reduced. Parcels are gripped and lifted to the correct height in one swift movement. All control functions are built into a compact handle.



## Fixed Hood

Fitting an hood to the tail end of the conveyor raises the belt, enabling loose-loaded cargo to travel from the boom over the hood and up to another belt. This option provides a smooth transition to whatever handling system is installed.



## Portal Light

Usually, lighting inside the truck is poor. Fixing a portal light to the last section of the conveyor provides sufficient lighting for the operator to be able to see what he is doing. The portal light is an integral part of the machine, extending and retracting together with the boom.



## DroopSnoot

In principle, the DroopSnoot is a special section mounted at the head of the boom. Equipped with a standard control panel, the operator is able to use the joystick to elevate the DroopSnoot to an appropriate position, enabling the goods to be loaded/unloaded ergonomically.

When the conveyor is not in use, the DroopSnoot can be stored in an upright position. When stored in this manner the droop snoot adds 0.5 m to the length of the base section.



## Man Rider Platform

This solution is ideal for unloading/loading Timpet Super Cube or other specialised trailers. This option ensures ergonomic operating conditions by providing a platform for the operator to stand on. Using the joystick at the head of the boom, the operator can extend the conveyor and adjust elevation so that he is positioned precisely where he needs to be. Foot pedal operation is optional. The platform is equipped with a safety hand-rail, clamp for restraining harness and chain plus an

anti-slip floor plate to prevent the operator falling from the platform.

Safety stops ensure that platform movement is restricted to the operating area, to prevent the operator from knocking into the sides of the container.

The Man Rider Platform can be used by one or two operators.

## Other Options include:

- Head lamp
- Side guards
- Tail conveyor
- Pivot
- Castors

and many more. Please ask for details.



## Description

Caljan BeltTrack can be floor mounted, dedicated to a particular door, or fitted with a rail carriage so that it can be moved parallel to the doors in the loading zone, as required.

## Design

Made of micro steel alloy, the conveyor frame is designed to withstand the harsh environment of the loading/unloading zone. All moving parts are protected to meet the latest safety regulations. Trolleys fitted with double bearings help spread the load of the telescopic sections whilst the booms are extending, providing correct extension and uniform high performance throughout the conveyors lifetime. The telescopic extension and retraction is powered by a gear motor to ensure smooth and safe movement.

The machine is fully guarded on the underside for optimal safety.

## Technical Data

Belt width:	600 or 800 mm
Belt type:	HQ-multiply PVC belt
Belt direction:	Loading or Unloading
Belt drive:	Gear motor
Telescopic movement:	Gear motor
Load:	50 kg/m
Power supply:	3 x 400 V AC, 50 Hz
Machine operation:	Power on/off at the rear of the conveyor Belt start and stop at the head of the conveyor

Control panel:	Can be fitted on either side at the head of the conveyor
Joystick:	Positioned on either side at the head of the conveyor. Pushing the joystick extends the conveyor. Pressure must be maintained to ensure safe operation
Safety features:	Emergency stop, both at the tail and head of the conveyor  Safety pop-out rollers (non driven) at the head of the conveyor  All moving parts are fully covered, including the underside of the conveyor  Rubber covers and brushes prevent pinching  Anti collision strip at the head of the conveyor
Communication:	Exchange signals can be sent from the conveyor to your package handling system and/or vice versa
Installation Environment:	Temperature 0-40°C Humidity 35-85% rH
Noise level:	65 dB(A) - highest value, measured at a distance of 1 m
Colour:	Standard RAL 3020. Other RAL colours available on request



www.caljanritehite.com

**Denmark**  
Caljan Rite-Hite ApS  
Ved Milepaelen 6-8  
DK-8361 Hasselager  
Aarhus  
Tel. +45 87 38 78 00  
Fax +45 87 38 78 01

**Germany**  
Caljan Rite-Hite GmbH  
Industriestraße 7  
D-65439 Flörsheim  
Tel. +49 6145 93490  
Fax +49 6145 934930

**UK**  
Caljan Rite-Hite Ltd  
Moorbridge Road  
Bingham Industrial Estate  
Nottingham NG13 8GG  
Tel. +44 (0) 1949 838 850  
Fax +44 (0) 1949 836 953

**France**  
Caljan Rite-Hite S.A.R.L.  
8, Rue Georges Besse  
ZAC du Fossé Pâté  
F-78330 Fontenay-le-Fleury  
Tél +33 1 30 07 12 37  
Fax +33 1 30 23 05 69

**Benelux**  
Caljan Rite-Hite BV  
Engelenburgstraat 57  
7391 AM Twello  
Tel. +31 (571) 270 444  
Fax +31 (571) 270 555

**USA**  
Caljan Rite-Hite Inc.  
3600 E. 45th Avenue  
Denver, CO 80216  
Tel. +1 303 321 3600  
Fax +1 303 321 6767